

No.	E2EC-2718
ISSUED:	JUN. 14, 2005
REVISED:	APR. 22, 2011



 **HOSHIZAKI**
SELF-CONTAINED FLAKER
MODEL FM-80EE(-N)

PARTS LIST
(HE)

NOTE : For "H-0", See "G-0"

E-0 JUN. 2005
F-0 DEC. 2005
F-1 APR. 2006
G-0 JUN.. 2007
H-0 JAN. 2008
K-2 APR. 2010
K-3 DEC. 2010

AUXILIARY CODE

U - 1

The auxiliary code is the first two characters in the serial number. The first character indicates the production year. Years progress or regress in alphabetical order. The series of letters and skipped letters depend on UL listing, production, and model. See the auxiliary code(s) and corresponding year(s) on the front cover.

The second character indicates significant part changes within the same year. Base is "1" and this number advances for each change. If there is no significant part change at the turn of the year, this number starts from "0."

MARKS LOCATED UNDER THE AUXILIARY CODE

- = Part deleted.
- x = Part deleted and replaced by "o" part.
- o = New part in place of "x" part.

FASTENER PART NUMBER

SCREWS



F S T 0 3 0 6 F 0

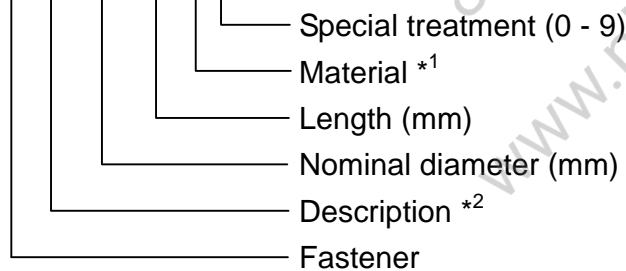

*¹ Material

- F: Steel
- S: Austenitic stainless steel
- M: Martensitic stainless steel
- B: Copper alloy
- P: Polycarbonate
- N: Polyamide
- V: PVC
- A: ABS
- X: Polyacetal
- L: Aluminum

NUTS & WASHERS

F W S P 0 5 S 0

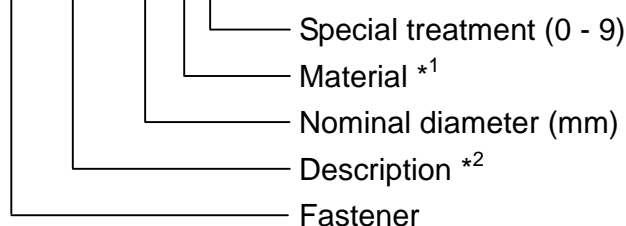

*² Description

- First letter
- S: Machine screw
- T: Tapping screw
- M: Wood screw
- B: Bolt
- W: Washer
- N: Nut

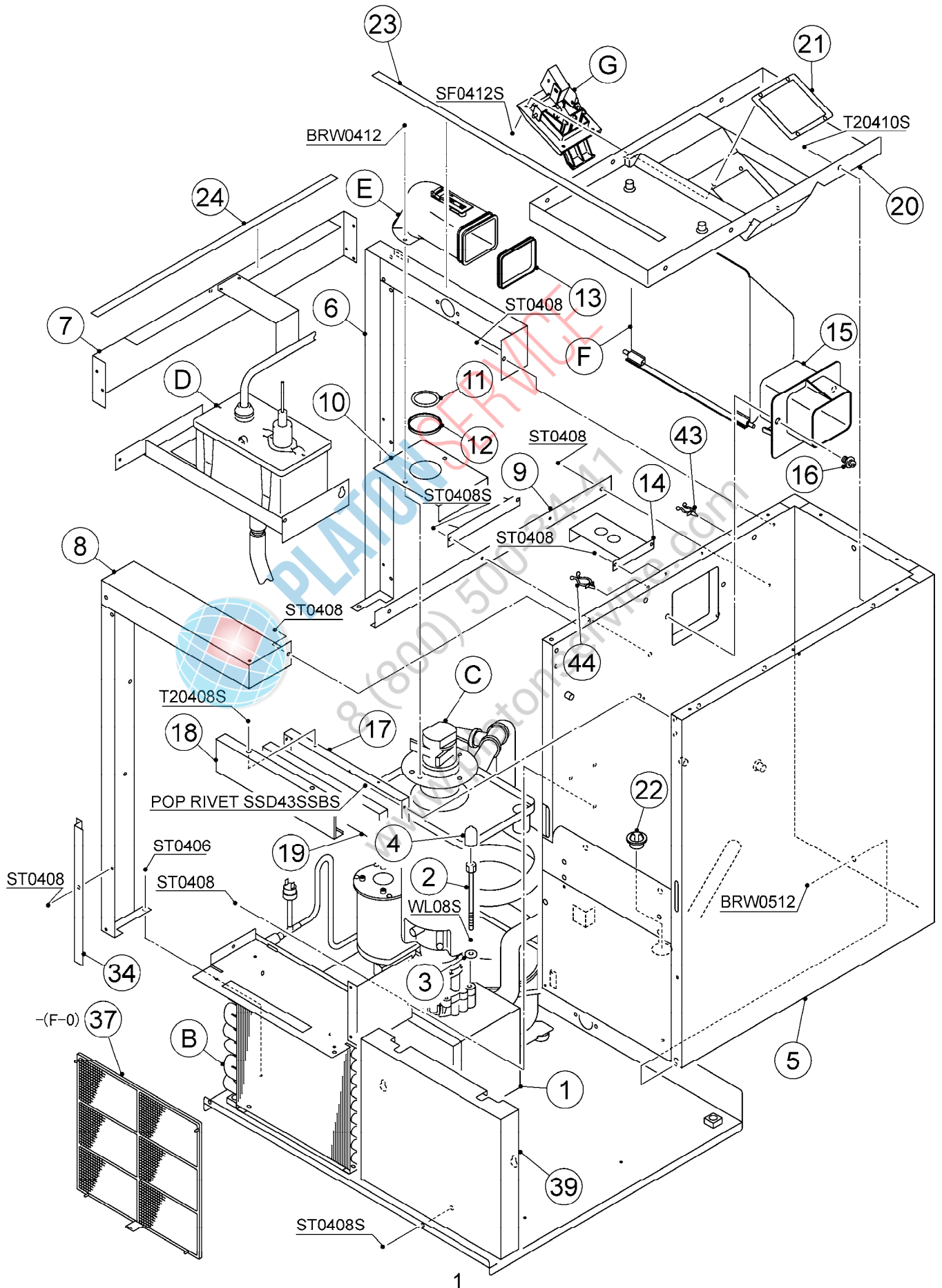

FM-80EE, FM-80EE(UK),
FM-80EE-N

A. ICE FLAKER ASSY(1/2)

(K-3) and later

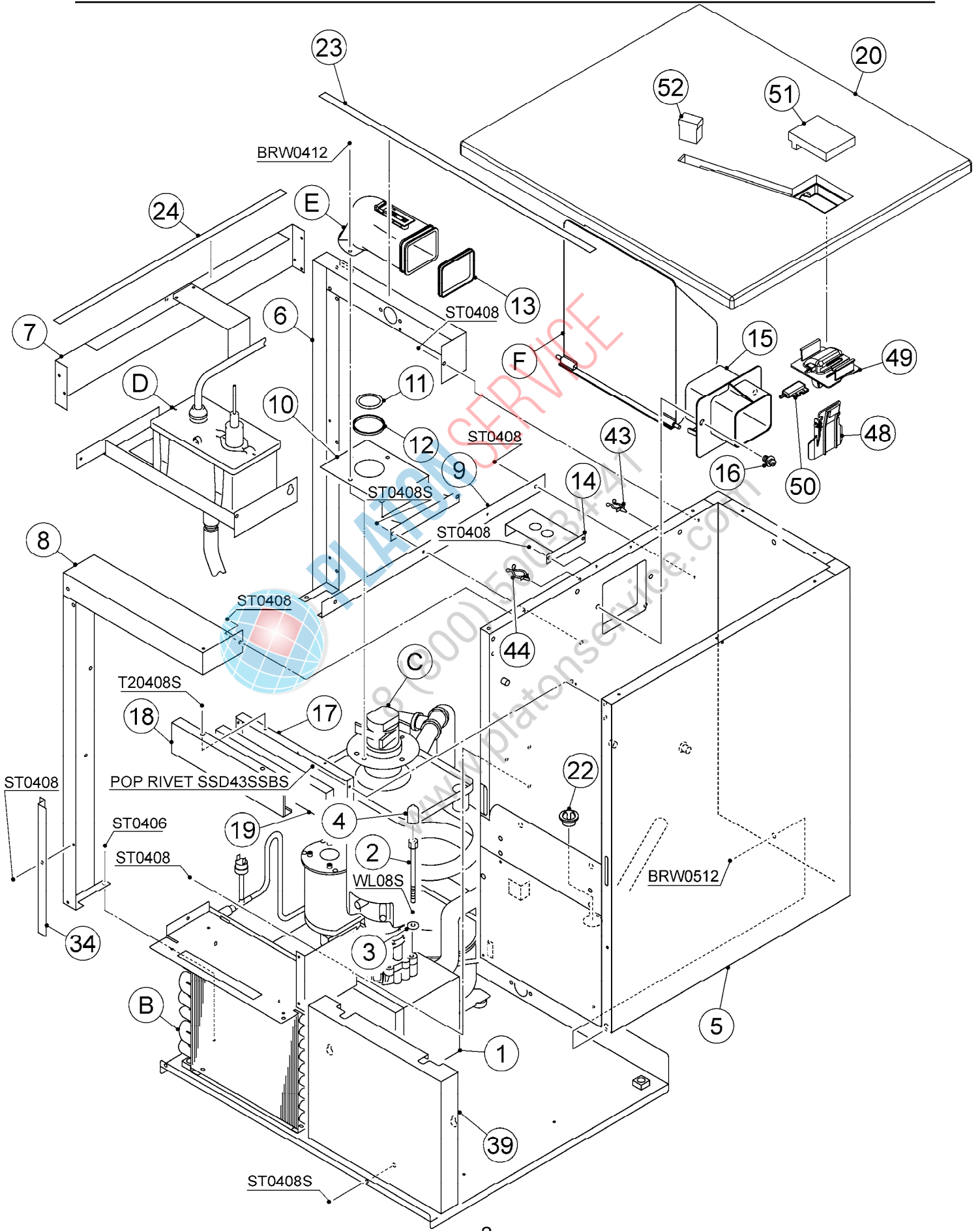

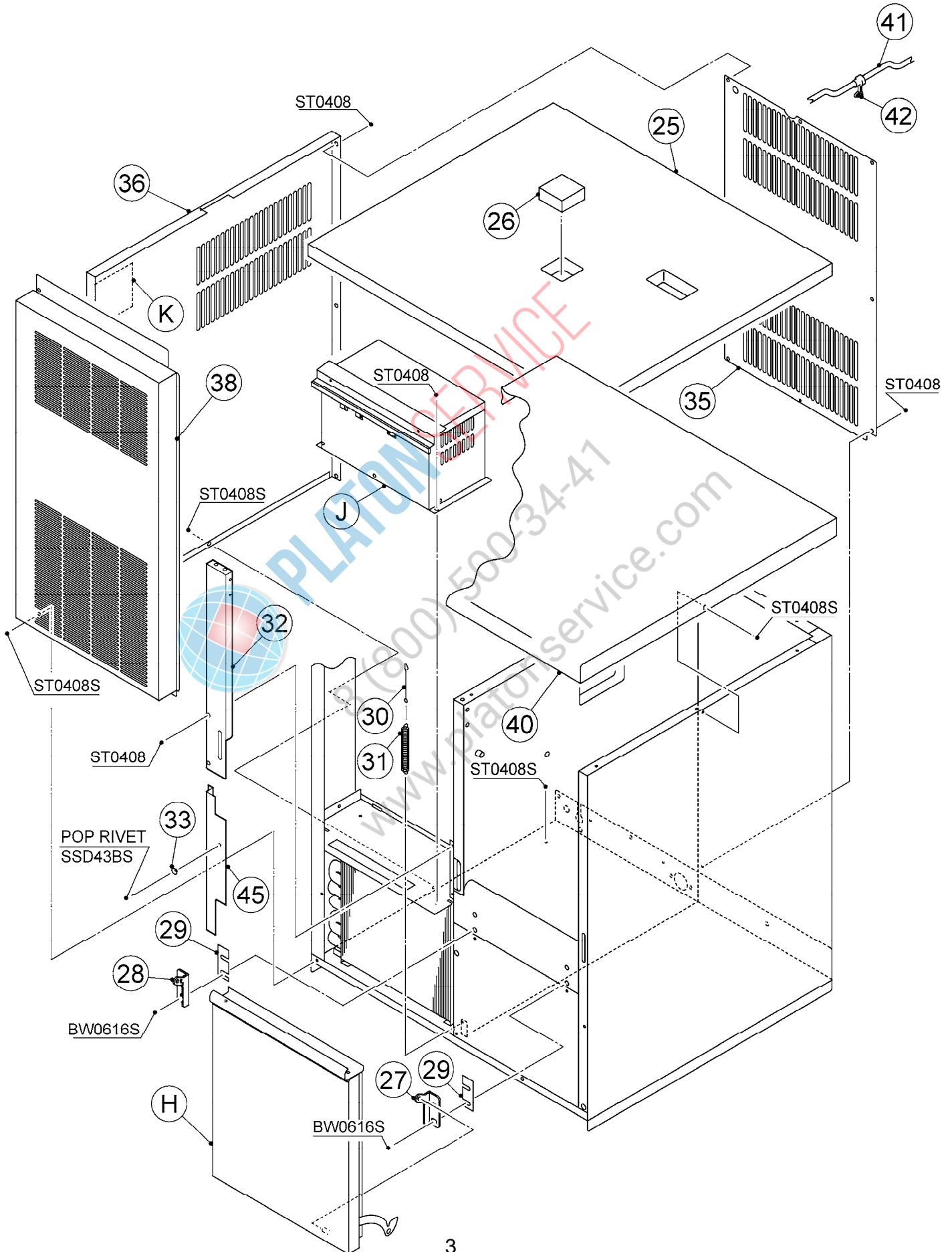

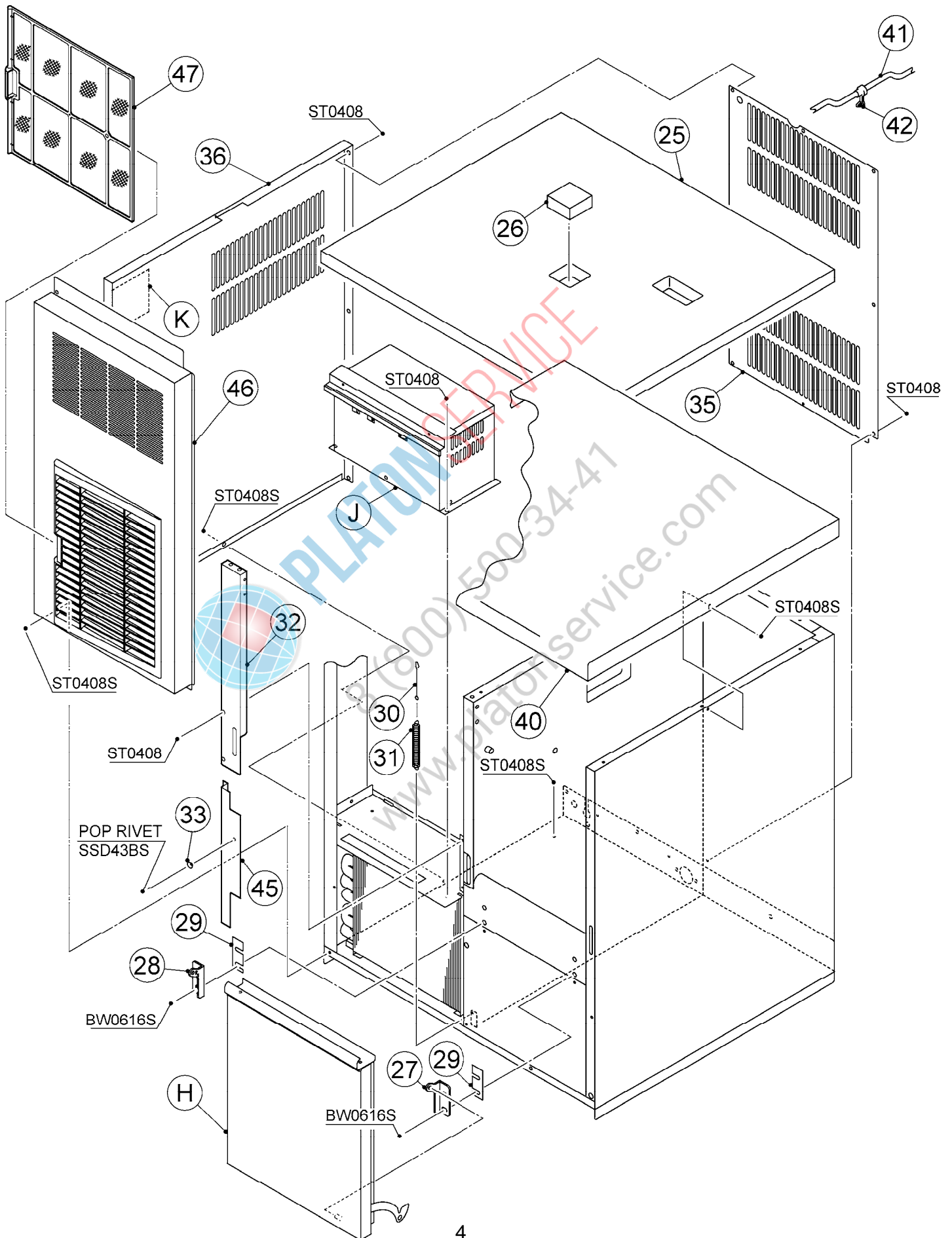

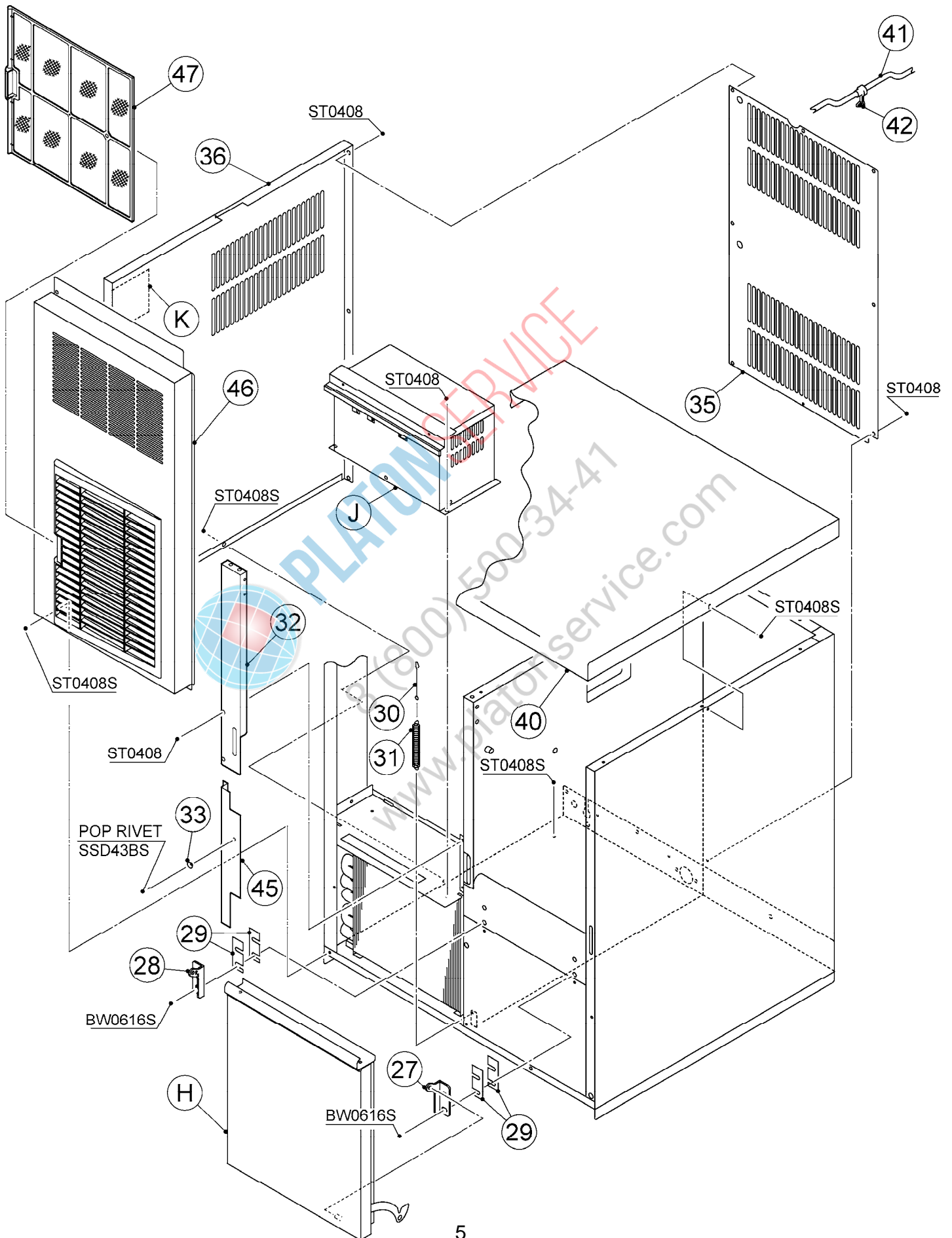

HE

MODEL: FM-80EE, FM-80EE(UK)		TITLE: A. ICE FLAKER ASSY						
FM-80EE-N								
INDEX NO.	DESCRIPTION	MATERIAL OR MODEL NUMBER	PART NUMBER	REQ'D NUMBER				
				E-0	F-0	F-1	G-0, K-1	K-2
B	REFRIGERATION CIRCUIT		115833A01	1	1	1	1	1
C	ICE MAKING UNIT	FM-80EE	363134A01	1	1	1	1	1
		FM-80EE(UK)						
		FM-80EE-N	363134001	-	1	1	1	1
D	WATER CIRCUIT		115737A01	1	1	1	1	1
E	SPOUT ASSY		358941A01	1	1	1	1	1
F	SLOPE		362588G01	1	1	1	1	1
G	BIN SWITCH ASSY	(S-0360)	310810A01	1	1	1	1	1
H	DOOR ASSY		358877A01	1	1	1	1	×1
			373745A01					○1
J	CONT. BOX ASSY		245551A01	1	1	-		
			245551A02			1	1	1
K	LABEL LOCATION	FM-80EE	245552A01	1	1	1	1	1
		FM-80EE(UK)						
		FM-80EE-N	245552A02	-	1	1	1	1
1	GEAR MOTOR BASE		241751G01	1	1	1	1	1
2	SCREW - M8	8 x 93	458298-03	3	3	3	3	3
3	SEAL WASHER	8	458299-01	3	3	3	3	3
4	VINYL CAP		451272-01	3	3	3	3	3
5	BIN - FOAMED		115726G01	1	1	1	1	1
6	REAR FRAME		245370-01	1	1	1	1	1
7	SIDE FRAME		362978-01	1	1	1	1	1
8	FRONT FRAME(L)		245372-01	1	1	1	1	1
9	BRACE - EVAPORATOR		466287-01	1	1	1	1	1
10	BRACKET - EVA		358886-01	1	1	1	1	1
11	O RING		7616-G045	1	1	1	1	1
12	RING		432661-03	1	1	1	1	1
13	PACKING(A)		427152-02	1	1	1	1	1
14	SWITCH LEVER		466286-01	1	1	1	1	1
15	SPOUT(B)		232654-02	1	1	1	1	1

HE

MODEL: FM-80EE, FM-80EE(UK)		TITLE: A. ICE FLAKER ASSY						
FM-80EE-N								
INDEX NO.	DESCRIPTION	MATERIAL OR MODEL NUMBER	PART NUMBER	REQ'D NUMBER				
				E-0	F-0	F-1	G-0, K-1	K-2
16	BOLT		462612-01	2	2	2	2	2
17	FRONT FRAME - BIN		466313-01	1	1	1	1	1
18	FRONT FRAME - BIN		466312-01	1	1	1	1	1
19	INSULATION - FRONT		418332-01	1	1	1	1	1
20	UPPER PANEL - BIN		241746-01	1	1	1	1	1
21	FRAME - BIN SWITCH		466617-01	1	1	1	1	1
22	DRAIN PIPE - CUT		466275-01	1	1	1	1	1
23	SOFT TAPE	t3 x w15 x L635 SUPER SEAT HG	115832-43	2	2	2	2	2
24	SOFT TAPE	t3 x w15 x L530 SUPER SEAT HG	115832-44	3	3	3	3	3
25	INSULATION (A) - TOP		358885-01	1	1	1	1	1
26	INSULATION (B) - TOP		466314-01	1	1	1	1	1
27	HINGE (RIGHT)		4H0456-01	1	1	1	1	1
28	HINGE (LEFT)		426053-01	1	1	1	1	1
29	HINGE SPACER (B)		4H0605-02	2	2	2	2	2
30	HOOK(H)		404060-07	1	1	1	1	1
31	SPRING		4H0491-01	1	1	1	1	1
32	FRONT PLATE		358898-01	1	1	1	1	1
33	TAPER COLLAR		4H0171-01	2	2	2	2	2
34	BARRIER - AIR		466295-01	1	1	1	1	1
35	REAR PANEL (L)		245047-01	1	1	1	1	1
36	SIDE PANEL(L)		245044-01	1	1	1	1	1
37	AIR FILTER		332631G01	1	1	-		
38	FRONT PANEL (L)		245043-01	1	1	-		
39	FRONT PANEL (R)		362595-01	1	1	1	1	1
40	TOP PANEL		241759-01	1	1	1	1	1
41	POWER CORD	FM-80EE	452263-01	1	1	1	1	1
		FM-80EE(UK)	4X3521G01	1	1	1	1	1
42	BUSHING	CEE SR-6P-10	448949-01	1	1	1	1	1
43	CLAMP	No. 249	427902-03	5	5	5	5	5
44	CLAMP	No. 4253	427902-05	4	4	4	4	4

HE

MODEL: FM-80EE, FM-80EE(UK)		TITLE: A. ICE FLAKER ASSY						
FM-80EE-N								
INDEX NO.	DESCRIPTION	MATERIAL OR MODEL NUMBER	PART NUMBER	REQ'D NUMBER				
				E-0	F-0	F-1	G-0, K-1	K-2
45	BARRIER - AIR (B)		468195-01	1	1	1	1	1
46	FRONT PANEL		249060G01			1	1	1
47	AIR FILTER (B)		2A2063G01			1	1	1

HE

MODEL: FM-80EE, FM-80EE(UK)		TITLE: A. ICE FLAKER ASSY					
FM-80EE-N							
INDEX NO.	DESCRIPTION	MATERIAL OR MODEL NUMBER	PART NUMBER	REQ'D NUMBER			
				K-3			
B	REFRIGERATION CIRCUIT		115833A01	1			
C	ICE MAKING UNIT	FM-80EE	363134A01	1			
		FM-80EE(UK)					
		FM-80EE-N	363134001	1			
D	WATER CIRCUIT		115737A01	1			
E	SPOUT ASSY		358941A01	1			
F	SLOPE		362588G01	1			
G	BIN SWITCH ASSY	(S-0360)	310810A01	-			
H	DOOR ASSY		373745A01	1			
J	CONT. BOX ASSY		245551A02	1			
K	LABEL LOCATION	FM-80EE	245552A01	1			
		FM-80EE(UK)					
		FM-80EE-N	245552A02	1			
1	GEAR MOTOR BASE		241751G01	1			
2	SCREW - M8	8 x 93	458298-03	3			
3	SEAL WASHER	8	458299-01	3			
4	VINYL CAP		451272-01	3			
5	BIN - FOAMED		115726G01	-			
			258347G01	1			
6	REAR FRAME		245370-01	1			
7	SIDE FRAME		362978-01	1			
8	FRONT FRAME(L)		245372-01	1			
9	BRACE - EVAPORATOR		466287-01	1			
10	BRACKET - EVA		358886-01	1			
11	O RING		7616-G045	1			
12	RING		432661-03	1			
13	PACKING(A)		427152-02	1			
14	SWITCH LEVER		466286-01	1			
15	SPOUT(B)		232654-02	1			
16	BOLT		462612-01	2			
17	FRONT FRAME - BIN		466313-01	1			

HE

MODEL: FM-80EE, FM-80EE(UK)		TITLE: A. ICE FLAKER ASSY					
FM-80EE-N							
INDEX NO.	DESCRIPTION	MATERIAL OR MODEL NUMBER	PART NUMBER	REQ'D NUMBER			
				K-3			
18	FRONT FRAME - BIN		466312-01	1			
19	INSULATION - FRONT		418332-01	1			
20	UPPER PANEL - BIN		241746-01	-			
			258350G01	1			
21	FRAME - BIN SWITCH		466617-01	-			
22	DRAIN PIPE - CUT		466275-01	1			
23	SOFT TAPE	t3 x w15 x L635 SUPER SEAT HG	115832-43	2			
24	SOFT TAPE	t3 x w15 x L530 SUPER SEAT HG	115832-44	3			
25	INSULATION (A) - TOP		358885-01	-			
26	INSULATION (B) - TOP		466314-01	-			
27	HINGE (RIGHT)		4H0456-01	1			
28	HINGE (LEFT)		426053-01	1			
29	HINGE SPACER (B)		4H0605-02	4			
30	HOOK(H)		404060-07	1			
31	SPRING		4H0491-01	1			
32	FRONT PLATE		358898-01	1			
33	TAPER COLLAR		4H0171-01	2			
34	BARRIER - AIR		466295-01	1			
35	REAR PANEL (L)		245047-01	1			
36	SIDE PANEL(L)		245044-01	1			
37	AIR FILTER		332631G01				
38	FRONT PANEL (L)		245043-01				
39	FRONT PANEL (R)		362595-01	1			
40	TOP PANEL		241759-01	1			
41	POWER CORD	FM-80EE	452263-01	1			
		FM-80EE(UK)	4X3521G01	1			
42	BUSHING	CEE SR-6P-10	448949-01	1			
43	CLAMP	No. 249	427902-03	5			
44	CLAMP	No. 4253	427902-05	4			
45	BARRIER - AIR (B)		468195-01	1			
46	FRONT PANEL		249060G01	1			

HE

INDEX NO.	DESCRIPTION	MATERIAL OR MODEL NUMBER	PART NUMBER	REQ'D NUMBER				
				K-3				
47	AIR FILTER (B)		2A2063G01	1				
48	ACTUATOR		345878G01	1				
49	ACTUATOR BASE		345879-01	1				
50	REED SWITCH		453861-02	1				
51	INSULATION (A) - UP		458667-01	1				
52	INSULATION (B) - UP		458668-01	1				

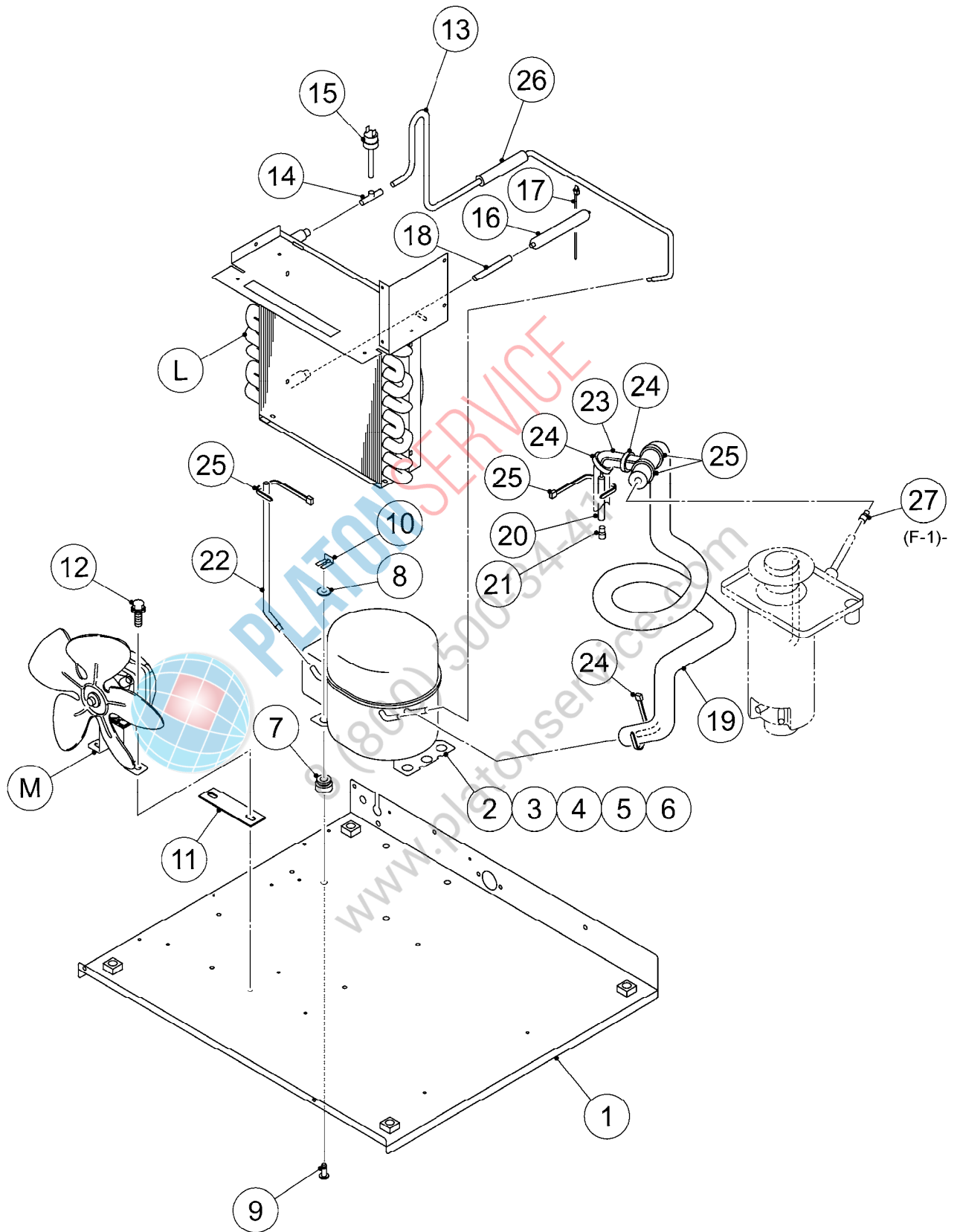

HE

MODEL: FM-80EE, FM-80EE(UK)		TITLE: B. REFRIGERATION CIRCUIT						
FM-80EE-N								
INDEX NO.	DESCRIPTION	MATERIAL OR MODEL NUMBER	PART NUMBER	REQ'D NUMBER				
				E-0	F-0	F-1	G-0, K-1	K-2 and later
L	CONDENSER ASSY		245549A01	1	1	1	1	1
M	FAN MOTOR ASSY	(S-9101)	3X1507A01	1	1	1	1	1
1	BASE		245546G01	1	1	1	1	1
2	COMPRESSOR	TLS6F	450900-01	1	1	1	1	1
3	STARTING RELAY	CM ACCESSORIES	451264-01	1	1	1	1	1
4	STARTING CAPACITOR	CM ACCESSORIES	452765-01	1	1	1	1	1
5	CORD RELIEF	CM ACCESSORIES	450899-01	1	1	1	1	1
6	COVER	CM ACCESSORIES	450896-01	1	1	1	1	1
7	RUBBER GROMMET		450897-01	4	4	4	4	4
8	WASHER		450894-01	4	4	4	4	4
9	STEEL PIN		452255-01	4	4	4	4	4
10	CLIP		452256-01	4	4	4	4	4
11	SPACER - FAN MOTOR		468443-01	1	1	1	1	1
12	HEX.BOLT SW	6 x 20	458660-01	2	2	2	2	2
13	COPPER TUBE(A) - HIGH SIDE		363814G01	1	1	1	1	1
14	TEE	8.16 DIA x 6.5 DIA x 6.5 DIA	420041-03	1	1	1	1	1
15	PRESSURE SWITCH	SEP-P180HHD-1	459863-02	1	1	1	1	1
16	DRIER	DY-10QHD-1	445655-01	1	1	1	1	1
17	TIE	RT30SSF5	457167-01	2	2	2	2	2
18	CHARGE TUBE	L=72	428058-05	1	1	-		
		L=72	469016-01			1	1	1
19	HEAT EXCHANGER		245547G01	1	1	1	1	1
20	COPPER TUBE - CAPILLARY		463885-02	1	1	1	1	1
21	REDUCER	9.52 x 8	421904-17	1	1	1	1	1
22	PROCESS TUBE - LOW SIDE		468444-01	1	1	1	1	1
23	INSULATION TUBE	L=300	7762-1030	1	1	1	1	1
24	CABLE TIE	CV-100	7920-0002	3	3	3	3	3
25	CABLE TIE	CV-150	7920-0003	12	12	12	12	12

HE

MODEL: FM-80EE, FM-80EE(UK)		TITLE: B. REFRIGERATION CIRCUIT						
FM-80EE-N								
INDEX NO.	DESCRIPTION	MATERIAL OR MODEL NUMBER	PART NUMBER	REQ'D NUMBER				
				E-0	F-0	F-1	G-0, K-1	K-2 and later
26	INSULATION TUBE	L=90	7762-1020	1	1	1	1	1
27	REDUCER		421904-23			1	1	1



PLATON SERVICE

8 (800) 500-34-47

www.platonservice.com

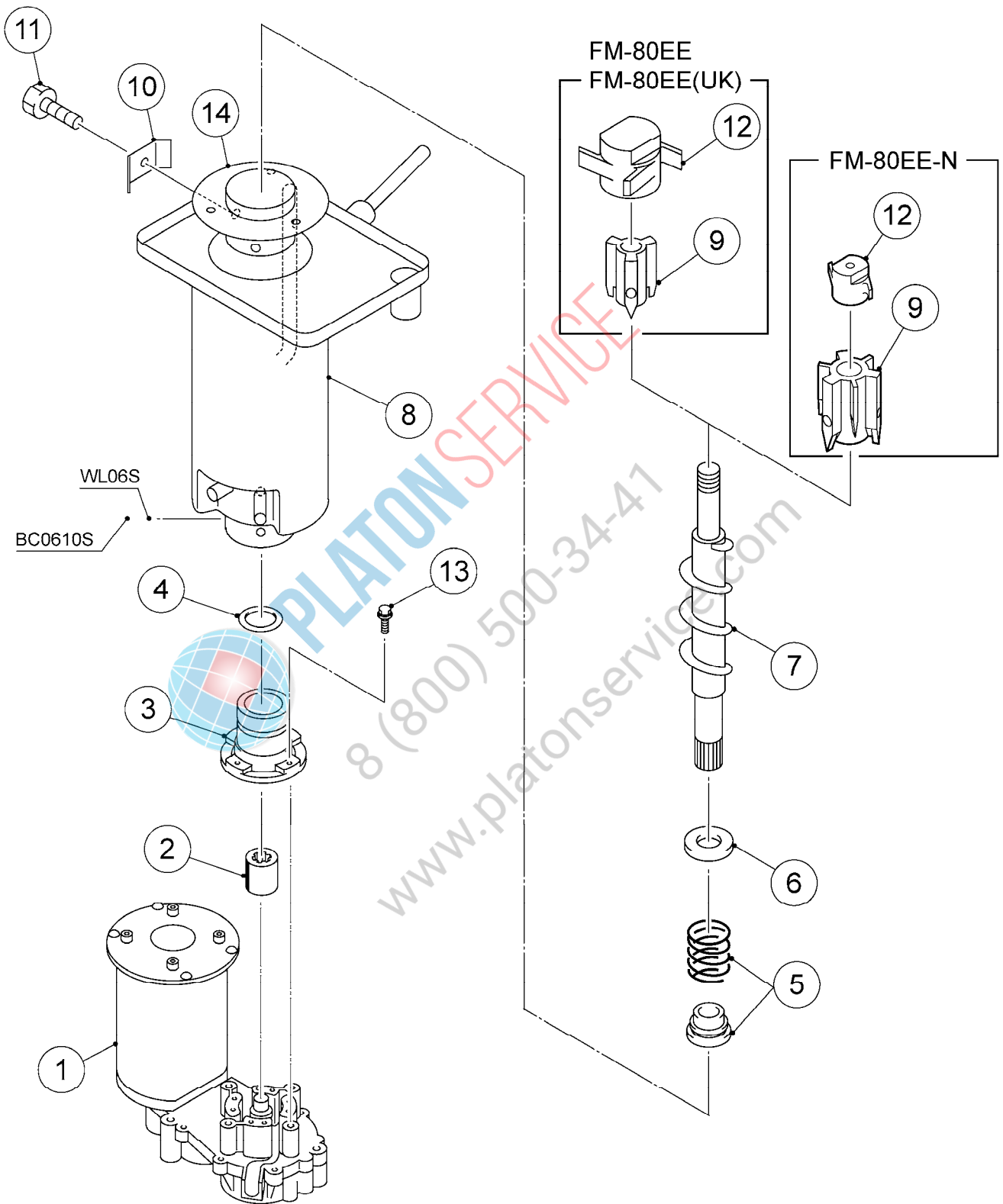

HE

MODEL: FM-80EE, FM-80EE(UK)		TITLE: C. ICE MAKING UNIT						
FM-80EE-N								
INDEX NO.	DESCRIPTION	MATERIAL OR MODEL NUMBER	PART NUMBER	REQ'D NUMBER				
				E-0	F-0	F-1	G-0, K-1	K-2 and later
1	GEAR MOTOR	TC1152	457758-01	1	1	1	1	1
2	COUPLING-SPLINE ASSY		418316-01	1	1	1	1	1
3	HOUSING		206013G05	1	1	1	1	1
4	O RING		7616-G040	1	1	1	1	1
5	MECHANICAL SEAL		432491-01	1	1	1	1	1
6	RING(B)		432494-01	1	1	1	1	1
7	AUGER		341446G01	1	1	1	x1	
			361013G01				o1	1
8	EVAPORATOR		233009G02	1	1	1	x1	
			241041G02				o1	1
9	EXTRUDING HEAD-45F	FM-80EE FM-80EE(UK)	327140G01	1	1	1	1	1
	EXTRUDING HEAD-45N	FM-80EE-N	327141G01	-	1	1	1	1
10	WASHER	SUS 8 x 14	427138-01	3	3	3	x3	
11	SEALBOLT-M8		P01768-01	3	3	3	3	3
12	4 CUTTER	FM-80EE FM-80EE(UK)	427137-01	1	1	1	1	1
	CUTTER	FM-80EE-N	440905-01	-	1	1	1	1
13	HEX.BOLT SW	6 x 20	458660-01	4	4	4	4	4
14	FLANGE/45		464843-01				1	1

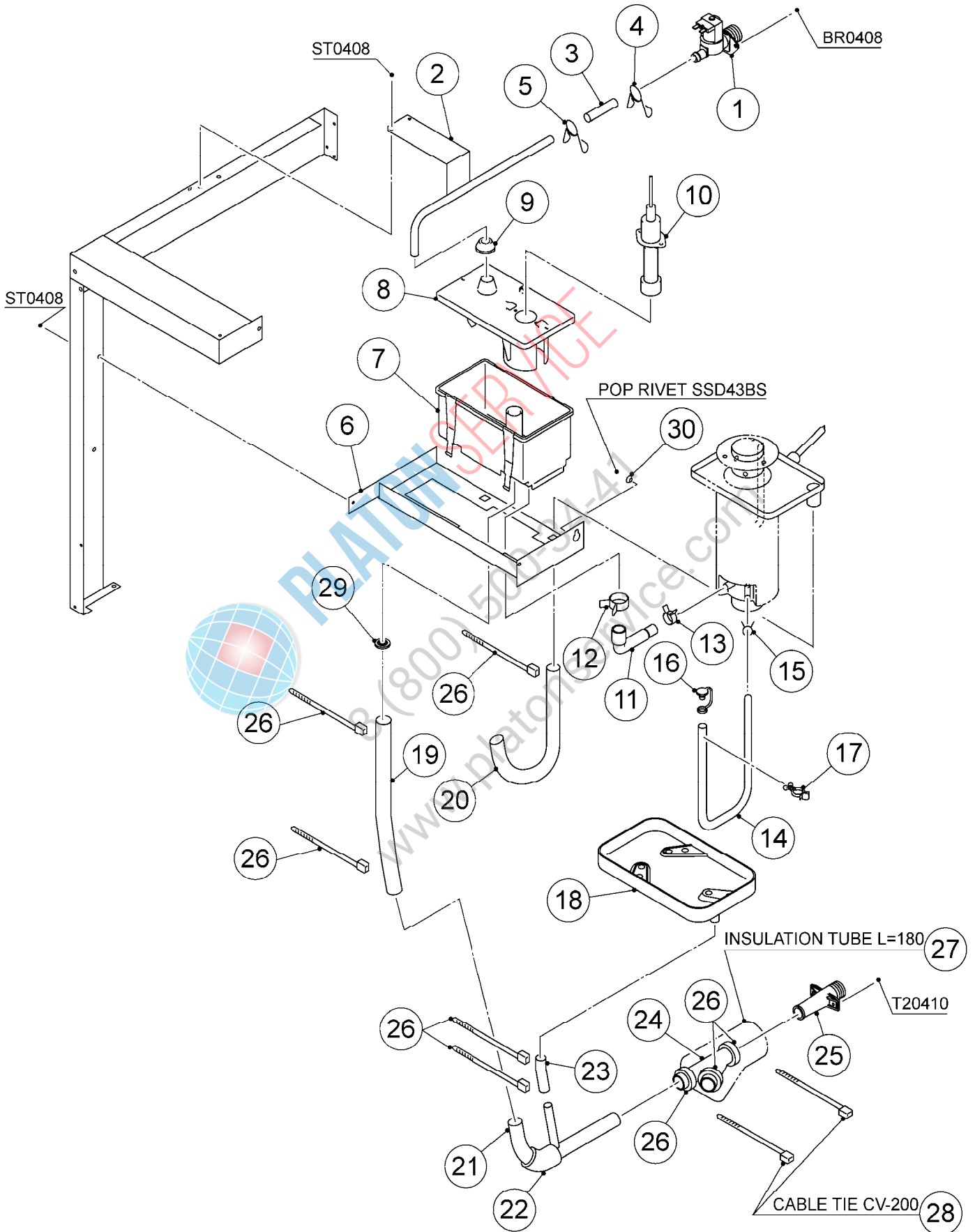

HE

MODEL: FM-80EE, FM-80EE(UK)		TITLE: D. WATER CIRCUIT						
FM-80EE-N								
INDEX NO.	DESCRIPTION	MATERIAL OR MODEL NUMBER	PART NUMBER	REQ'D NUMBER				
				E-0	F-0	F-1	G-0, K-1	K-2 and later
1	WATER VALVE	V183	452993-01	1	1	1	1	1
2	WATER SUPPLY PIPE		358887G01	1	1	1	1	1
3	SILICONE HOSE	L=60	7730-1114	1	1	1	1	1
4	HOSE CLAMP	SK-15	435934-03	1	1	1	1	1
5	HOSE CLAMP	SK-14	435934-02	1	1	1	1	1
6	RESERVOIR BRACKET		362979-01	1	1	1	1	1
7	RESERVOIR		232626-01	1	1	1	1	1
8	RESERVOIR COVER		232627-01	1	1	1	1	1
9	COVER RESERVOIR INLET		415094-01	1	1	1	1	1
10	FLOAT SWITCH		458279-02	1	1	x1		
			458279-01			o1	1	1
11	HOSE		458308-01	1	1	1	1	1
12	CLIP BAND	T21	423866-08	1	1	1	1	1
13	CLIP BAND	T15	423866-04	1	1	1	1	1
14	SOFT PVC HOSE	L=500	7716-0913	1	1	1	1	1
15	HOSE CLAMP	SK-13	435934-01	1	1	1	1	1
16	CAP		431689-01	1	1	1	1	1
17	CLAMP	No. 249	427902-03	1	1	1	1	1
18	DRAIN PAN		318155-01	1	1	1	1	1
19	VINYL HOSE	L=330	7711-2226	1	1	1	1	1
20	VINYL HOSE	L=440	7711-1923	1	1	1	1	1
21	DRAIN PIPE(A)		466285G01	1	1	1	1	1
22	INSULATION TUBE	L=60	7762-2343	1	1	1	1	1
23	VINYL HOSE	L=60	7711-1216	1	1	1	1	1
24	DRAIN JOINT		358882-01	1	1	1	1	1
25	DRAIN PIPE		321035-01	1	1	1	1	1
26	CABLE TIE	CV-150	7920-0003	8	8	8	8	8
27	INSULATION TUBE	L=180	7762-2636	1	1	1	1	1
28	CABLE TIE	CV-200	7920-0010	2	2	2	2	2
29	FILTER		4X1497G01	1	1	1	1	1

HE

MODEL: FM-80EE, FM-80EE(UK)		TITLE: D. WATER CIRCUIT						
FM-80EE-N								
INDEX NO.	DESCRIPTION	MATERIAL OR MODEL NUMBER	PART NUMBER	REQ'D NUMBER				
				E-0	F-0	F-1	G-0, K-1	K-2 and later
30	TAPER COLLAR		4H0171-01	1	1	1	1	1



PLATON SERVICE

8 (800) 500-34-47

www.platonservice.com

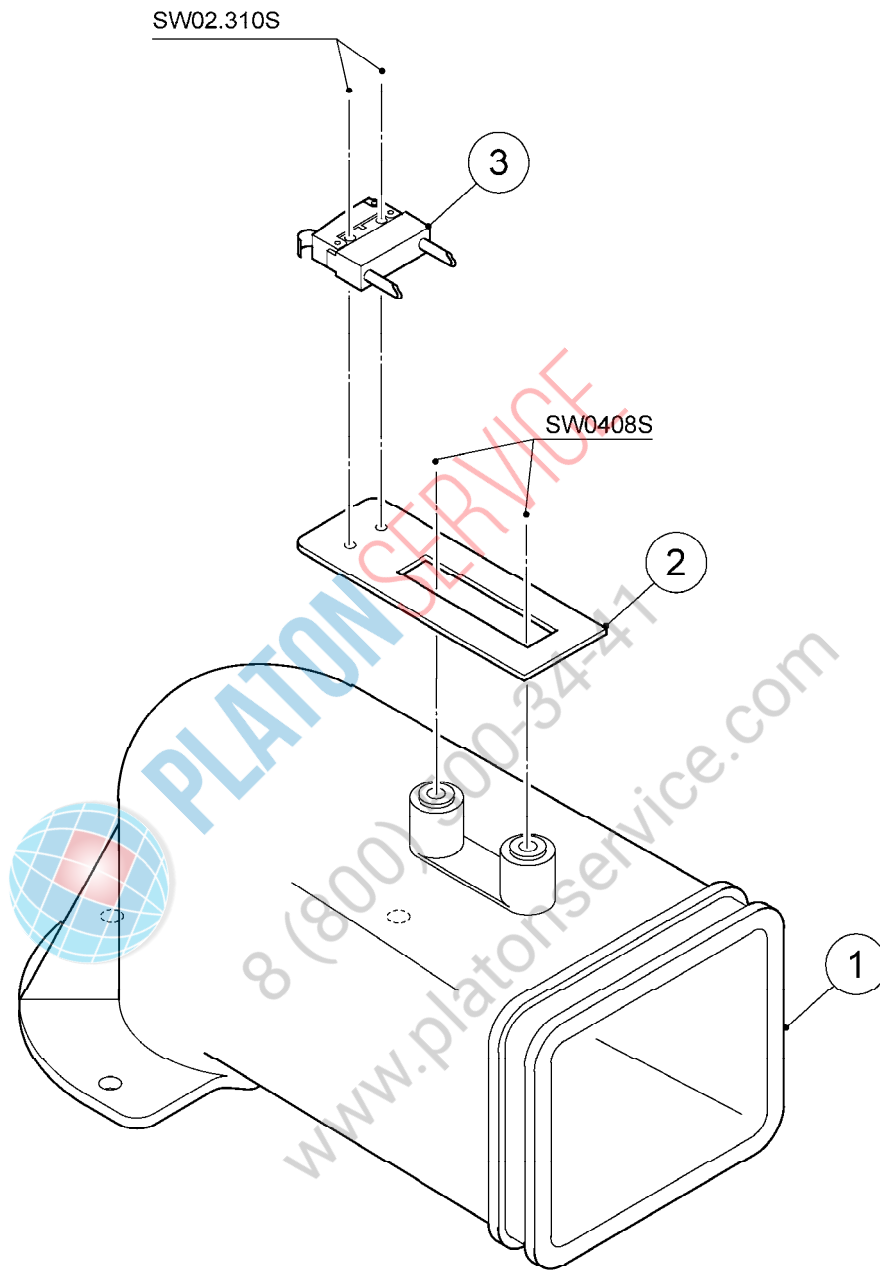

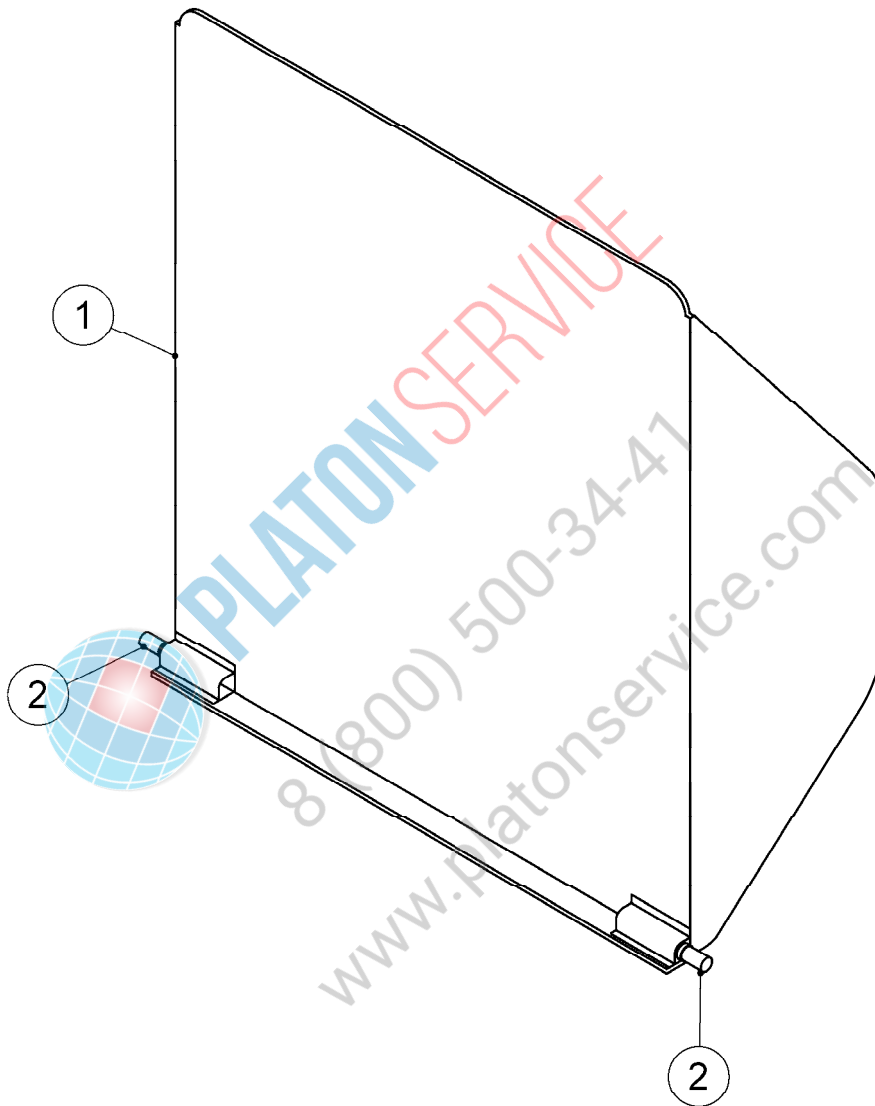

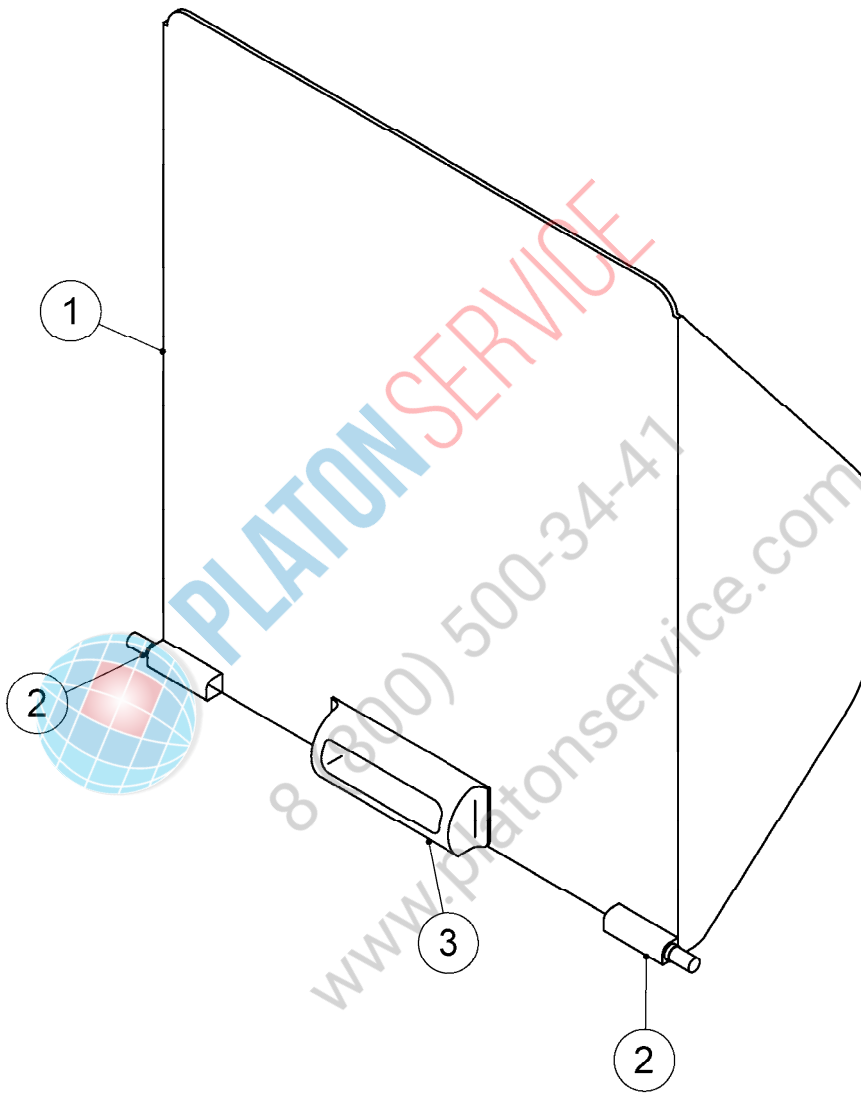

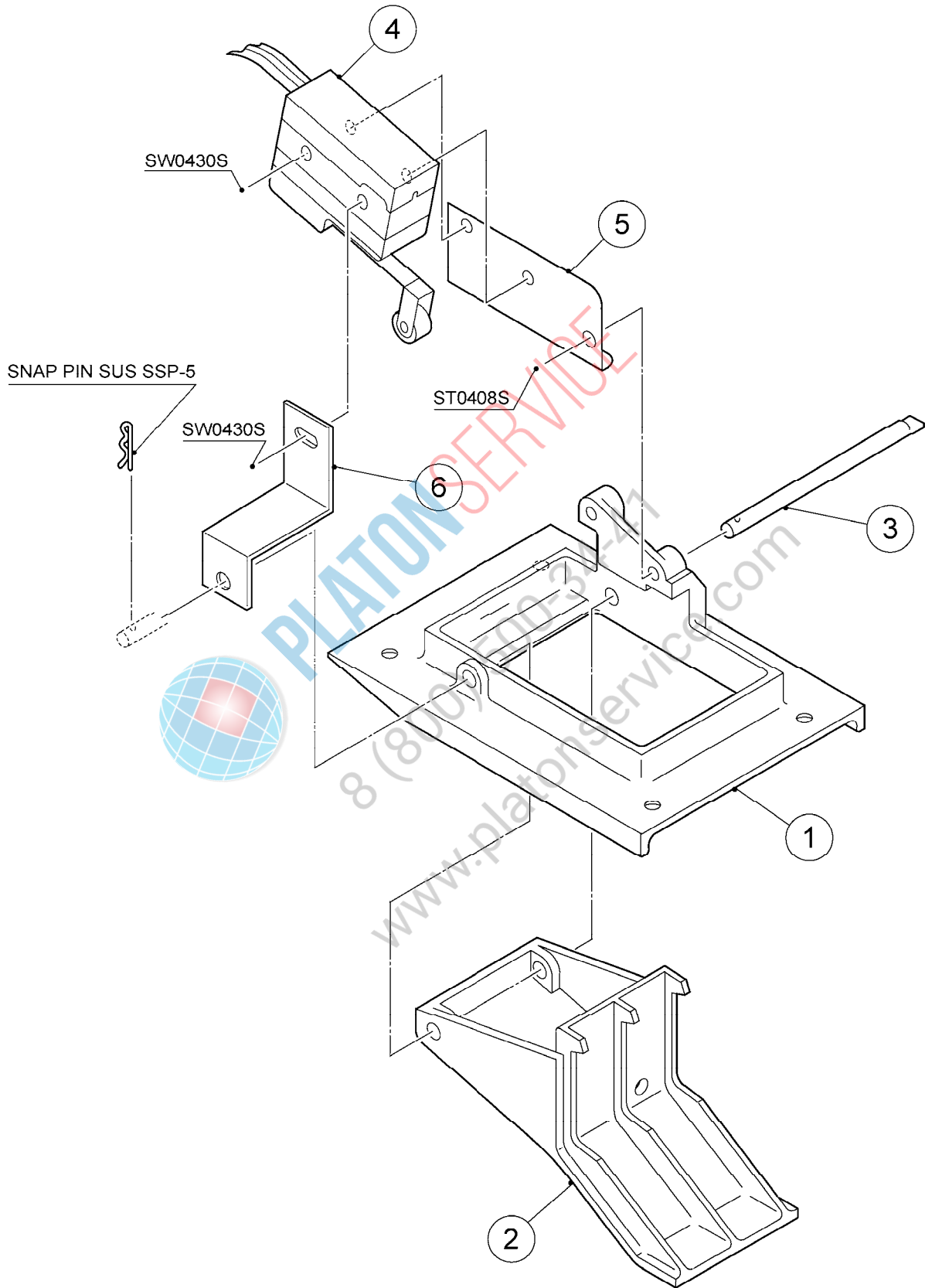

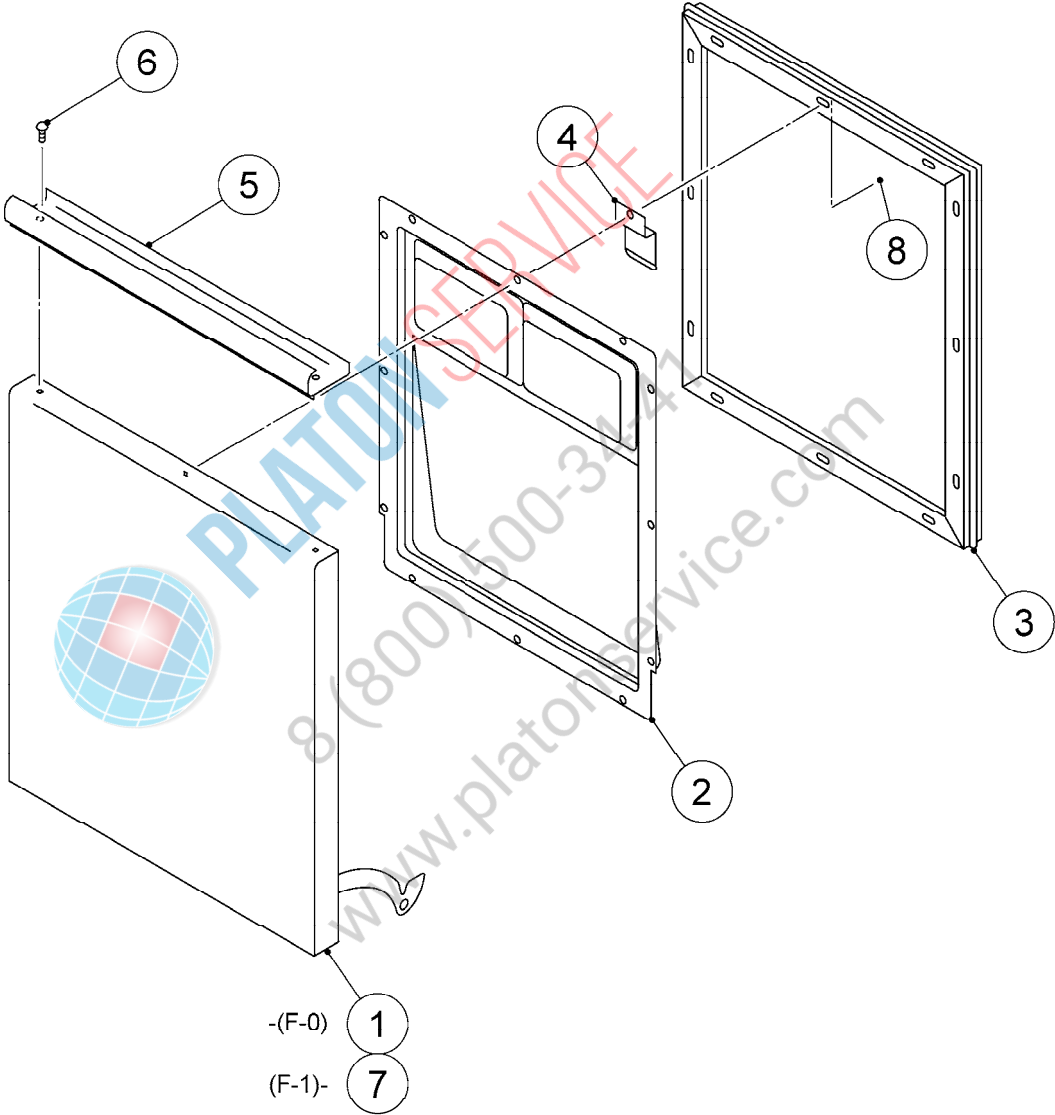

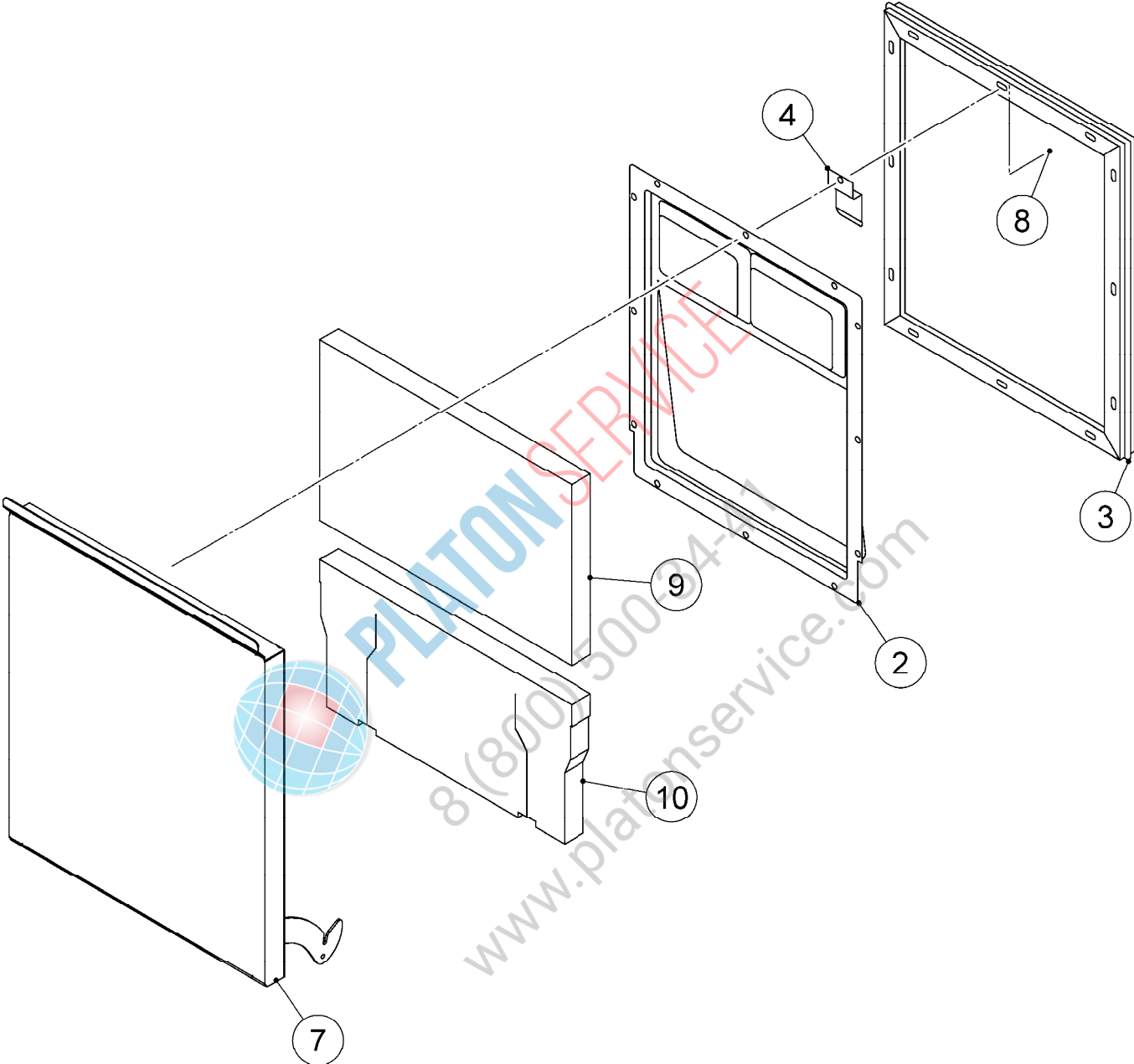

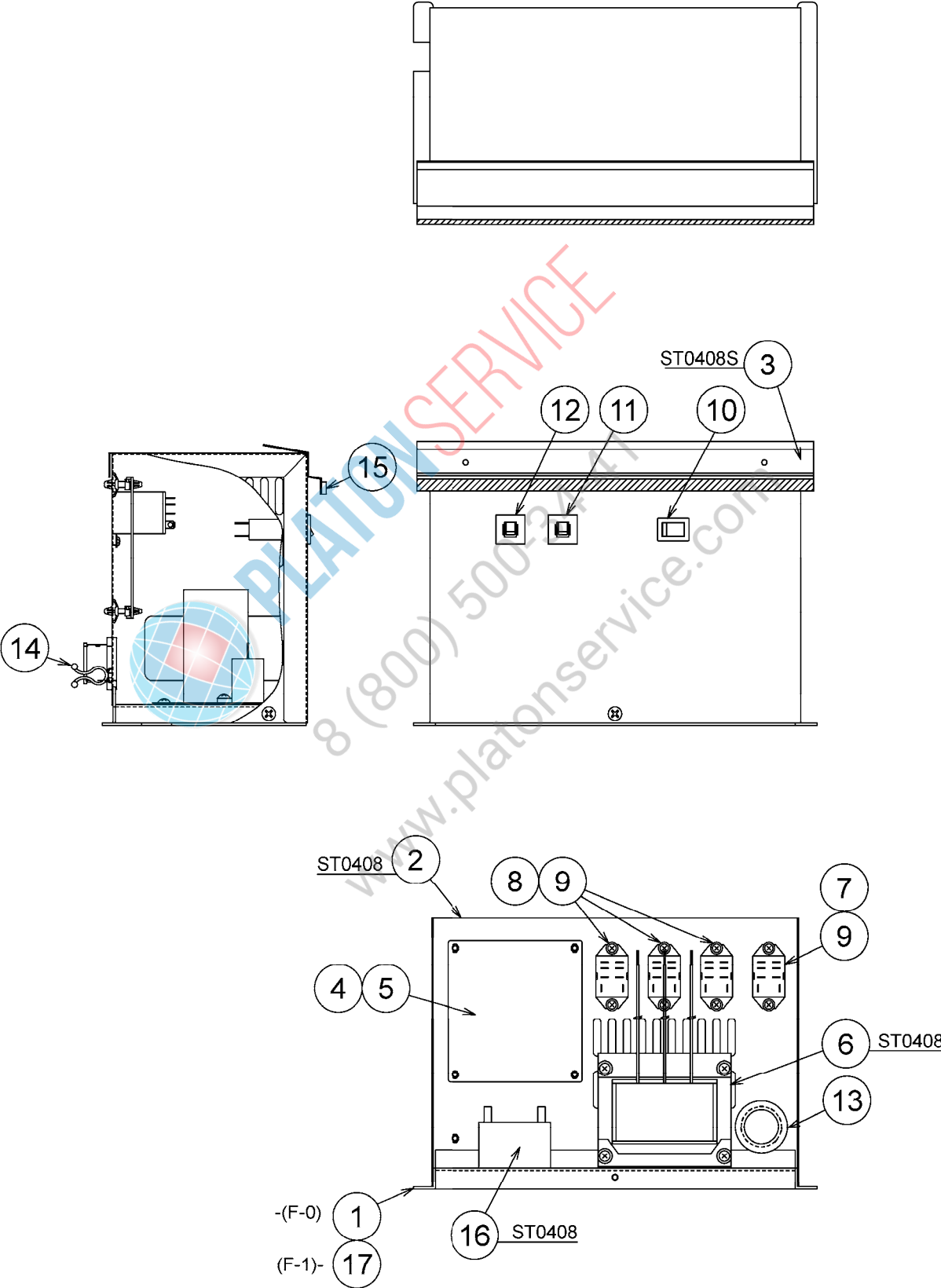

HE

MODEL: FM-80EE, FM-80EE(UK)		TITLE: J. CONTROL BOX ASSY						
FM-80EE-N								
INDEX NO.	DESCRIPTION	MATERIAL OR MODEL NUMBER	PART NUMBER	REQ'D NUMBER				
				E-0	F-0	F-1	G-0, K-1	K-2 and later
1	CONTROL BOX (A)		363135-01	1	1	-		
2	CONTROL BOX (B)		362487-01	1	1	1	1	1
3	COVER - CONT. BOX		362489G01	1	1	1	1	1
4	TIMER BOARD	H2AA144C02	437305-02	1	1	1	1	1
5	BOARD SUPPORT	KGLS-6S	414929-01	4	4	4	4	4
6	TRANSFORMER	TR004	464147-01	1	1	1	1	1
7	RELAY	LY2F AC100V	406132-01	1	1	1	1	1
8	RELAY	LY2ZF AC24V	406132-06	3	3	3	3	3
9	TAPPING SCREW	3 x 8	431415-01	8	8	8	8	8
10	ROCKER SWITCH	SLE6A2	446719-02	1	1	1	1	1
11	PROTECTOR	W28XQ1A-1	440972-06	1	1	1	1	1
12	PROTECTOR	W28XQ1A-6	440972-03	1	1	1	1	1
13	GROMMET		4H2568-01	1	1	1	1	1
14	CLAMP	No. 249	427902-03	2	2	2	2	2
15	SEAL TAPE	W8 x t3.2	245551-20	1	1	1	1	1
16	CAPACITOR	CME 25B805DX	457870-01	1	1	1	1	1
17	CONTROL BOX (A)		366964-01			1	1	1

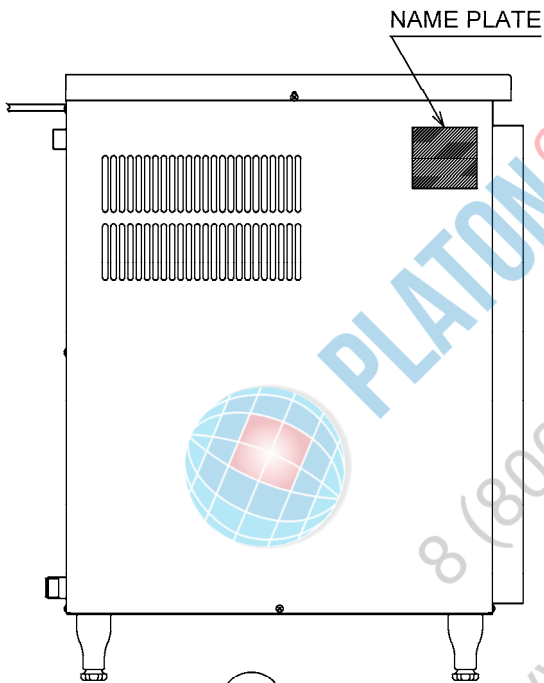
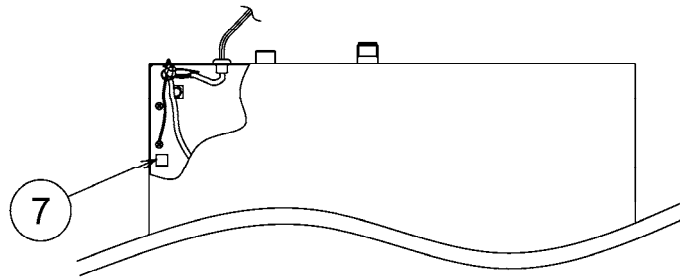

DETAIL LABEL-TERMINAL

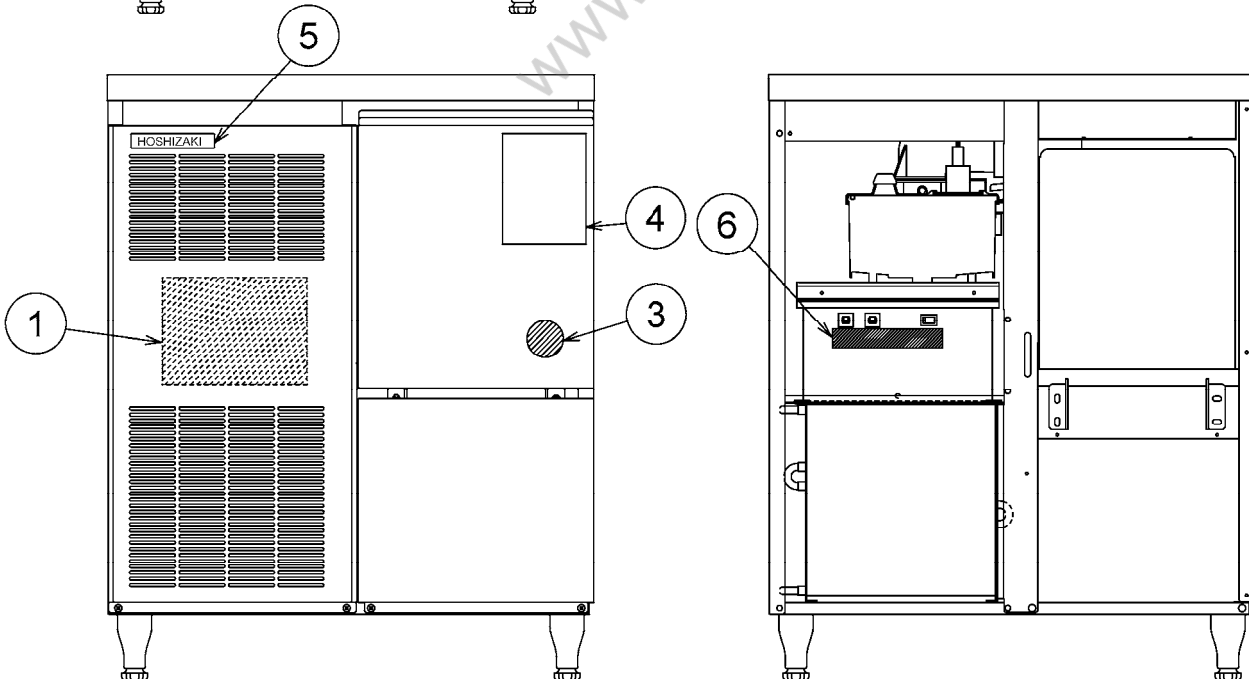
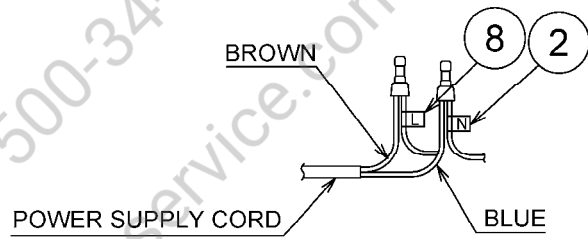

HE

MODEL: FM-80EE, FM-80EE(UK) FM-80EE-N				TITLE: K. LABEL LOCATION				
INDEX NO.	DESCRIPTION	MATERIAL OR MODEL NUMBER	PART NUMBER	REQ'D NUMBER				
				E-0	F-0	F-1	G-0, K-1	K-2 and later
1	WIRING LABEL		363136-01	1	1	1	1	1
2	LABEL-TERMINAL		452379-04	1	1	1	1	1
3	LABEL-PENGUIN(L)		454387-02	1	1	1	1	1
4	MAINTENANCE LABEL		455837-01	1	1	1	x1	
5	EMBLEM-HE		356509-01	1	1	1	1	1
6	OPERATION LABEL		468514-01	1	1	1	1	1
7	LABEL-GROUND		450452-02	1	1	1	1	1
8	LABEL-TERMINAL		452379-03	1	1	1	1	1

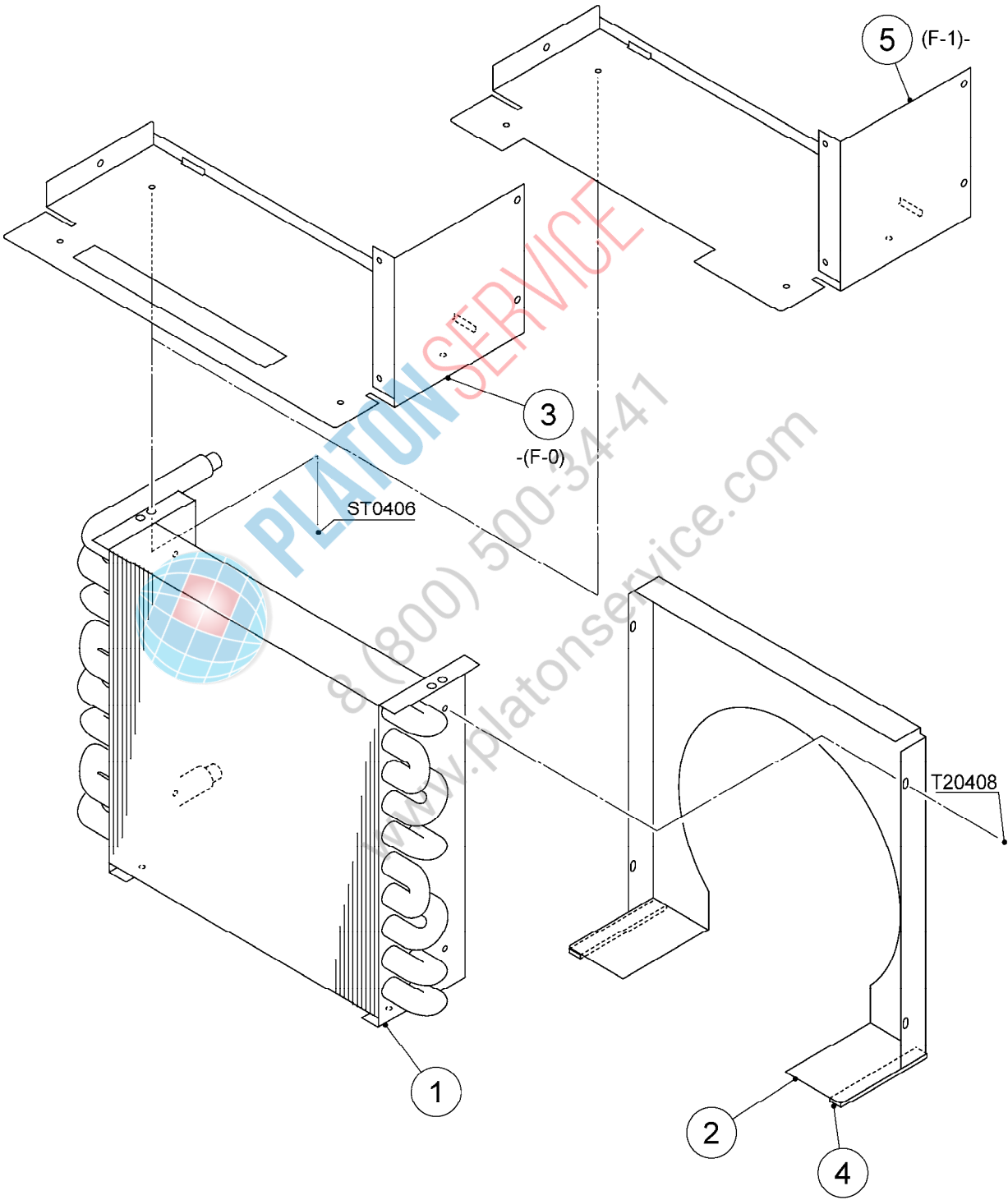

HE

MODEL: FM-80EE, FM-80EE(UK)		TITLE: L. CONDENSER ASSY						
FM-80EE-N								
INDEX NO.	DESCRIPTION	MATERIAL OR MODEL NUMBER	PART NUMBER	REQ'D NUMBER				
				E-0	F-0	F-1	G-0, K-1	K-2 and later
1	CONDENSER - AIR COOLED		2H5655-01	1	1	1	1	1
2	SHROUD		363133-01	1	1	1	1	1
3	BRACKET - CONT.BOX		362486-01	1	1	-		
4	SOFT TAPE	t3.2 x W10 x L80	245549-06	2	2	2	2	2
5	BRACKET - CONT.BOX		366960-01			1	1	1

